



Corrosion Behavior of Galvanized Steel Embedded in Concrete Exposed to Soil Type MH Contaminated With Chlorides

Miguel Angel Baltazar-Zamora^{1*}, José Manuel Mendoza-Rangel², René Croche³, Citlalli Gaona-Tiburcio⁴, Cindy Hernández⁵, Luis López⁶, Francisco Olguín⁶ and Facundo Almeraya-Calderón⁴

¹ Facultad de Ingeniería Civil - Xalapa, Universidad Veracruzana, Xalapa, Mexico, ² FIC, Universidad Autónoma de Nuevo León, San Nicolás de los Garza, Mexico, ³ FIME - Xalapa, Universidad Veracruzana, Xalapa, Mexico, ⁴ FIME-CIIIA, Universidad Autónoma de Nuevo León, San Nicolás de los Garza, Mexico, ⁵ ASPHALTPAVE S.A. DE C.V., Xalapa, Mexico, ⁶ Universidad Autónoma del Estado de Hidalgo, Hidalgo, Mexico

OPEN ACCESS

Edited by:

David M. Bastidas,
University of Akron, United States

Reviewed by:

Jian Chen,
University of Western Ontario, Canada
Benjamin Salas Valdez,
Universidad Autónoma de
Baja California, Mexico

*Correspondence:

Miguel Angel Baltazar-Zamora
mbaltazar@uv.mx

Specialty section:

This article was submitted to
Environmental Materials,
a section of the journal
Frontiers in Materials

Received: 25 July 2019

Accepted: 26 September 2019

Published: 11 October 2019

Citation:

Baltazar-Zamora MA,
Mendoza-Rangel JM, Croche R,
Gaona-Tiburcio C, Hernández C,
López L, Olguín F and
Almeraya-Calderón F (2019)
Corrosion Behavior of Galvanized
Steel Embedded in Concrete Exposed
to Soil Type MH Contaminated With
Chlorides. *Front. Mater.* 6:257.
doi: 10.3389/fmats.2019.00257

The behavior of corrosion in reinforced concrete, buried in a soil type silt of higher plastic (MH), the present study represents the conditions of exposure that can find the foundations of infrastructure such as bridges, buildings, pavements, when in contact with a soil that could contain aggressive agents like chlorides and sulfates. In such concrete specimens a carbon steel bar AISI 1018 and Galvanized Steel was embedded as reinforcement, the mixed concrete was of ratio water/cement (w/c) = 0.45 (compressive strength, $f'c$ = 350 kg/cm²), according to ACI 211.1, using cements Portland Cement Composite [CPC 30R (Type I) and CPC 30R RS (Type V)]. The used electrochemical techniques such as Corrosion Potentials (ASTM C-876-15) and Linear Polarization Resistance. LPR (ASTM-G59). The specimens were buried in a soil type MH contaminated with 0, 1, 2, and 3 wt.% NaCl as aggressive agent by weight of soil, the exposure time was 260 days where, the results show that when the presence of NaCl in the soil was increased to 2 and 3% the levels of corrosion are from high to very high in all concretes, presenting a little better performance the concretes reinforced with galvanized steel and a small benefit could be identified or related to the properties of a denser and less impermeable matrix that presented the concrete mix made with cement CPC 30R RS.

Keywords: corrosion, concrete, galvanized steel, soil type MH, chlorides

INTRODUCTION

The problem of corrosion of steel reinforcement in concrete structures has been extensively studied since the 50's. Is a very important problem, because the service lifetime of a reinforced concrete structure can be reduced by corrosion of the embedded reinforcing steel. Such corrosion is due to aggressive agents which come from the ambient environment (Caré and Raharinaivo, 2007). External causes of a non-structural nature that often the durability of concrete structures are mainly consequence of their exposure and service conditions (Melchers and Li, 2009; Pradhan, 2014; Troconis de Rincon et al., 2016). Chloride ions are the main cause of corrosion of reinforced

concrete structures, these ions may be present in the components of the concrete mix (aggregates, cement, water, additives), or by the environment with which the concrete structure will be in contact, such as sea water, sewage water, industrial water, contaminated soils etc. (Criado et al., 2011; Mahyuddin et al., 2013; Monticelli et al., 2014). The chloride ions are capable of causing localized corrosion of the reinforcing steel and therefore to produce the premature and unexpected failure of the structure (Liang and Lan, 2005; Zuquan et al., 2007), being a determining factor the chlorides threshold, because the steel rebar inside reinforce concrete structures is susceptible to corrosion when permeation of chloride from deicing salts or seawater results in the chloride content at the surface of the steel exceeding a chloride threshold level (CTL) (Ann and Song, 2007; Babaee and Castel, 2018; Alonso et al., 2019).

Corrosion of Reinforced Concrete Structures is recognized as a problem of great economic and social importance, in the last decades has worked hard in trying to mitigate the effects of this phenomenon. There are countless works around the world dealing with the problem from different perspectives, from innovation in concrete and cement technology as lightweight concrete reinforced by steel fibers or synthetic fibers (Hung Mo et al., 2017), corrosion inhibitors, evaluation of corrosion concrete exposed in different aggressive environments (marine, urban, industrial) real and simulated (Fajardo et al., 2011; Zhang et al., 2011; Luoa et al., 2012; Zhu and François, 2013; Wang et al., 2014; Šavija and Lukovic, 2016; Sadrmomtazi et al., 2017), but one of those that has had more importance lately, is the replacement of AISI 1018 carbon steel bars with galvanized steel bars, several investigations have shown that concrete reinforced with Galvanized Steel present better performance in marine environments o when the concretes are previously contaminated with chloride agents (Kayali and Yeomans, 2000; Cheng et al., 2005; Bellezze et al., 2006).

Of the above it is possible to identify the magnitude and importance of the problem of the corrosion of reinforcing steel in concrete structures and it can be said that there is little information of the corrosion process in reinforced concrete when it is in contact with the subsoil (Santiago et al., 2016a; Shaheen and Pradhan, 2017; Zhao et al., 2018), like the piles a bridge, a foundation slab from a treatment or thermoelectric plant, as well as the effects on its mechanical properties (Adekunle et al., 2015).

The present work has the objective of evaluating the electrochemical behavior of reinforced concrete buried in a soil type MH contaminated with chlorides, simulating the conditions of concrete elements in contact with the subsoil, as are the foundations of most Civil Works that are built around the world, to be able to obtain parameters that allow us to assess the corrosive aggressiveness of the subsoil, to build more durable civil works and resistant to corrosion from their foundations.

MATERIALS AND METHODS

The specimens were placed in containers with the soil type MH contaminated with 0, 1, 2 and wt. 3% NaCl by weight of the soil, later to carry out the electrochemical evaluation using techniques

Corrosion Potentials and Linear Polarization Resistance as is done by the scientific community (Nuñez et al., 2012; Almeraya et al., 2013; Bastidas et al., 2015).

Design and Proportioning of Concrete Mixes

The design and proportioning of the concrete mix used was elaborated with the method of ACI 211.1 (ACI 211.1, 2004), this design methodology is based on the physical characteristics of fine and coarse aggregates, concrete compressive strength required (f'_c), the slump (workability or consistency) of concrete mix. For the physical characterization of the aggregates the tests are carried out according to ASTM standards, the tests were Bulk Density ("Unit Weight") (ASTM C29/C29M-07, 2007), Relative Density (Specific Gravity) and Absorption Coarse Aggregate and Fine Aggregate (ASTM C127-15, 2015; ASTM C128-15, 2015), Fineness modulus and Maximum Aggregate Size (ASTM C33/C33M-16e1, 2016), the **Table 1** show the physical characteristics of the materials used.

The **Table 2** shows the dosage obtained for a concrete mixture of $w/c = 0.45$ ratio ($f'_c = 350 \text{ kg/cm}^2$). Two concrete mixtures were made with the same proportion but with different type of portland cement composite, CPC 30R RS (Type V) and CPC 30R (Type I) according standard ONNCCE (NMX-C-414-ONNCCE-2014, 2014).

Characterization of Concrete in Fresh and Hardened State

The characterization of concrete mixtures in a fresh state were performed the Standards ONNCCE and ASTM, this test was the slump (NMX-C-156-ONNCCE-2010, 2010), temperature (ASTM C 1064/C1064M-08, 2008), density (NMX-C-162-ONNCCE-2014, 2014), and the results obtained for the two concrete mixtures are shown in **Table 3**.

The characterization of concrete mixtures in a hardened state, the tests were carried out according to the standard ONNCCE

TABLE 1 | Physical characteristics of the aggregates.

Physical characteristics	Coarse aggregate	Fine aggregate
Bulk density ("unit weight") in kg/m^3	1,389	1,294
Relative density (specific gravity)	2.41	2.52
Absorption (%)	3	2.77
Fineness modulus	–	2.4
Maximum aggregate size (mm)	19	–

TABLE 2 | Proportioning of concrete mixture 1 m^3 ($f'_c = 350 \text{ kg/cm}^2$).

Materials	Quantity in kg
Cement	456
Water	205
Coarse aggregate	913
Fine aggregate	838

(NMX-C-083-ONNCCE-2014, 2014), the results are presented in **Figure 1**, from which it can be seen that the concrete mix made with CPC 30R RS (Type V) presents the $F'c$ values higher than those reported for the concrete mix made with Cement CPC 30R (Type I), with a difference between the values of $F'c$, in each age at test, days 7, 14, and 28 of 4 to 6%, but decreasing this difference, in days 60 and 90 days, less than 5%, both concrete mixtures comply with the design resistance, $F'c = 350 \text{ kg/cm}^2$ at 28 days, with a $F'c = 371 \text{ kg/cm}^2$, the mixture made with CPC 30R RS and $F'c = 356 \text{ kg/cm}^2$ for the mixture made with CPC 30R. The results of the compressive strength test complied with the parameters of design for a concrete that can be used in Civil Works.

Characteristics of Test Specimens

The **Figure 2** shows the characteristics of the study specimens, which were reinforced with bars of AISI 1018 Carbon Steel and Galvanized Steel, which were the working electrodes (WE), and UNS S31600 (Type 316 stainless steel) as an Counter electrode (CE), this type of arrangement allows to evaluate the corrosion current density (I_{corr}) by the technique of linear polarization resistance (LPR) as indicated by the ASTM-G59 standard (ASTM G 59-97, 2014). The equipment Gill AC Galvanostat/Potentiostat/ZRA from ACM Instruments was used for these method (LPR), and with a standard copper-copper sulfate (Cu/CuSO_4) as reference electrode. The sweep potential was $\pm 20 \text{ mV}$ with respect to the E_{corr} and the sweep rate was 10 mV/min and the results were

analyzed using Version 4 Analysis specialized software from ACM Instruments.

All bars and were cleaned to remove any impurities that might have been present on them (Santiago et al., 2013; Landa et al., 2018a,b) and the manufacture of the test specimens was performed as indicated in the standard ASTM C 192 (ASTM C192/C192M-18, 2016).

The nomenclature used to perform the analysis of the results of E_{corr} and I_{corr} , is made up of 3 or 4 characters, having the following meaning:

- Ø, 1, 2, 3, indicates the percentage of NaCl present in soil type MH.
- R Indicate concrete mix made with CPC-30R (Type I).
- RS Indicate concrete mix made with CPC-30R RS (Type V).
- G bars of galvanized steel.
- C bars of AISI 1018 carbon steel.

Exposure of Specimens to Soil Contaminated MH Type

For the determination of the corrosion of concrete specimens reinforced with bars AISI 1018 carbon steel and galvanized steel, these specimens were buried in an MH soil, in the natural state (without of NaCl) and soil with 1%, 2% and 3 wt.% of NaCl by weight of soil, simulating a soil of marine environment.

It is important to note that this experimental arrangement is very little used in the study of corrosion of reinforcing steel in reinforced concrete structures, so the proposal in the present investigation is of great importance and innovation, since it simulates the situation of displacing the foundations of all types of civil Infrastructure, in soils where significant concentrations of aggressive agents such as chlorides and sulfates may be found, as commented in the introduction, there are few concrete corrosion studies carried out, considering to the soils as aggressive contact media for the elements such as footings, piles, foundation

TABLE 3 | Physical properties of concrete mixtures.

Test	CPC 30R (Type I)	CPC 30R-RS (Type V)
Temperature, °C	23	24
Slamp, cm	6	7
Density, kg/m^3	2,125	2,136

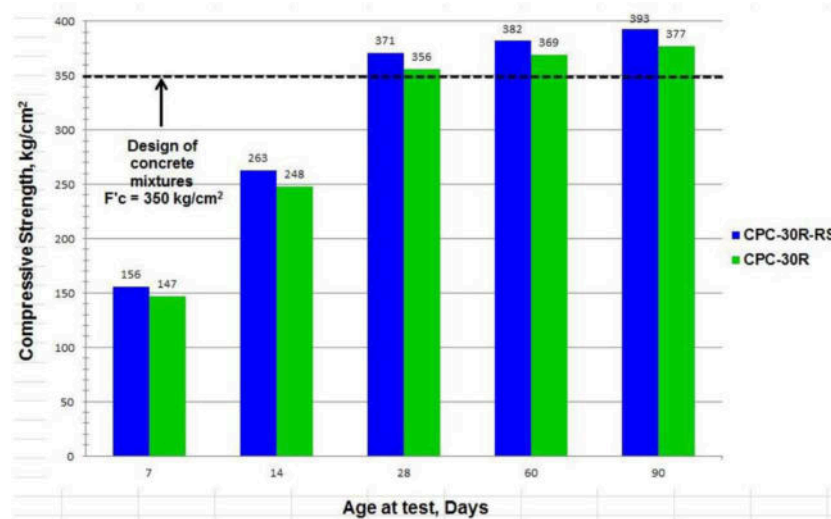

FIGURE 1 | Compressive strength concrete mixtures CPC 30R RS and CPC 30R.

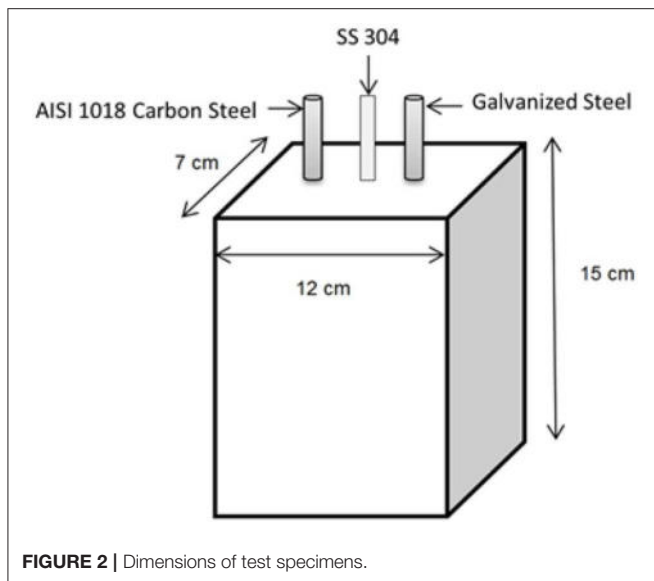

FIGURE 2 | Dimensions of test specimens.

TABLE 4 | Corrosion potential in reinforced concrete.

E_{corr} (mV) vs Cu/CuSO ₄	
> -200	10% Probability of corrosion
-350 a -200	Uncertainty
< -350	90% Probability of corrosion
< -500	Severe corrosion

slabs, which are the elements that support buildings, bridges, highways and industrial plants however, there are a large number of corrosion studies of reinforcing steel considering aggressive media such as seawater (Chaleea et al., 2009; Uthaman et al., 2017), solutions simulating marine or sulphated environments (Duarte et al., 2014; Santiago et al., 2016b), studies carried out *in situ*, with exposure to the atmosphere (De Vera et al., 2017; Kwon et al., 2017), investigations with alkaline solutions simulating the pore solution in the concrete (Williamson and Burkan, 2016; Verbruggen et al., 2017) etc.; for all the above, it is the relevance of the results obtained, analyzed and discussed in this research.

RESULTS AND DISCUSSION

Corrosion Potential (E_{corr})

The standard ASTM C876-15 (ASTM C 876-15, 2015), considering a more interval according to the literature (Song and Saraswathy, 2007), was used to perform the monitoring of the corrosion potential (E_{corr}) and interpretation of the probability of corrosion (see Table 4).

Figure 3 shows the results obtained from the monitoring of corrosion potentials (E_{corr}). Of the concrete specimens of ratio $w/c = 0.45$, exposed or buried to a predominant soil of the region of Xalapa, Ver., southeast Mexico, a fine soil type MH (Das, 2006), in the natural state without addition of NaCl. It is perfectly observed the difference between the two types of steel

used as reinforcement, AISI 1018 carbon steel commonly used in most reinforced concrete structures worldwide, with respect to Galvanized Steel. Both steels have a tendency from the curing stage to more positive values of E_{corr} , for the case of specimen ORC, this presents E_{corr} values in a range of -350 to -100 mV during the curing stage, to report E_{corr} values between -200 and -50 mV in the first 90 days of exposure in soil type MH in natural state, and continue with a tendency to present more positive E_{corr} values over time, reaching positive values of 10 mV at the end of the monitoring. The ORSC specimen exhibits a similar behavior to the ORC specimen, with a tendency toward more positive E_{corr} values throughout the exposure period, with E_{corr} values from -160 to -90 mV in the curing stage, presenting E_{corr} values lower than -200 mV during the entire exposure period, presenting at the end of the monitoring, a corrosion potential close to 10 mV; E_{corr} values presented by the ORC and ORSC specimens, when exposed to the soil type MH, indicating according to ASTM C-876-15 standard, a probability of 10% that the phenomenon of corrosion is being presented. Roventi et al. (2014) reported that the specimen with galvanized steel embedded in Ordinary Portland Concrete shows initial values of corrosion potential around -650 mV, while the bar embedded in Pozzolanic Concrete gives values around 100 mV SCE more negative, denoting a higher level of activity mainly due to the difference in pH between the concrete types, this behavior of higher activity level is presented in the ORSG and ORG specimens, as shown in Figure 3, having E_{corr} values for the galvanized steel embedded in concrete made with CPC 30R-RS) of -660 mV at the beginning of the monitoring, and -780 mV in concrete made with CPC 30R. This behavior contrasts with that reported in the literature (Baltazar et al., 2016), where it is evaluated the corrosion in concrete of ratio $w/c = 0.65$, reinforced with the same types of steels, AISI 1018 carbon steel and Galvanized Steel, but buried in a soil type SP of marine environment, presenting the specimens with steel AISI 1018 E_{corr} values between -200 and -350 mV after more than 200 days of exposure, and values between -350 and -500 mV for reinforced with galvanized steel, confirming the influence and aggressiveness of the marine environment soil in comparison to the soil type MH, without any addition of NaCl, soil in its natural state.

In Figure 4, it is shown as with only 1 wt.% of NaCl with respect to the weight of the soil type MH under study, this it presents corrosive aggressiveness compared to the soil in its natural state (Figure 3), when coming into contact with soil contaminated with 1 wt.% NaCl, all specimens have E_{corr} values that are more negative than those reported in Figure 3, soil type MH without NaCl. For this case, soil type MH with 1 wt.% of NaCl, the specimen what presented the most noble values of E_{corr} was the specimen 1RSC, elaborated with CPC-30R-RS cement and with AISI 1018 carbon steel as reinforcement, with E_{corr} values which vary between -350 and -200 mV, throughout the exposure period, indicating according ASTM C-876-15 standard, corrosion uncertainty in the system, a benefit can be identified, which is related to a mixture of concrete made with CPC 30R RS cement that showed a higher compression strength in all ages of testing, as shown in Figure 1, which are associated with a denser matrix and lower permeability, what benefits a better

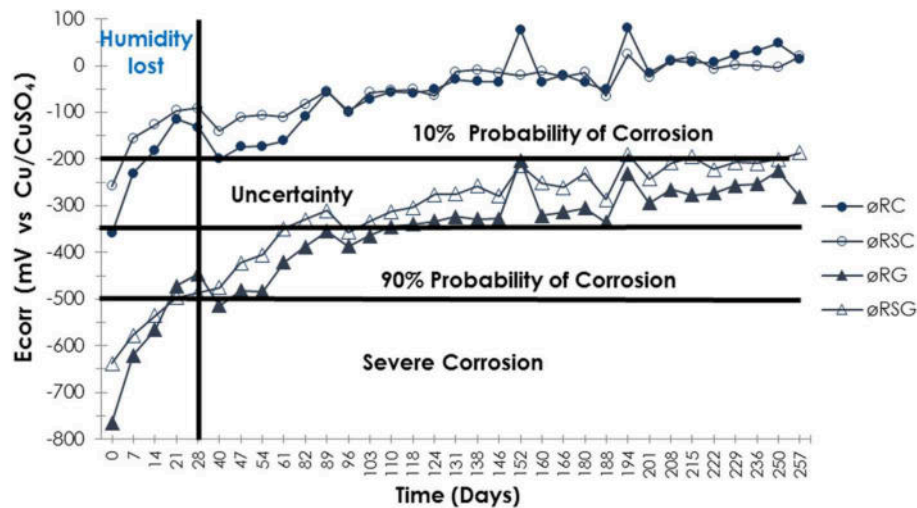

FIGURE 3 | E_{corr} specimens in soil type MH with 0% of NaCl.

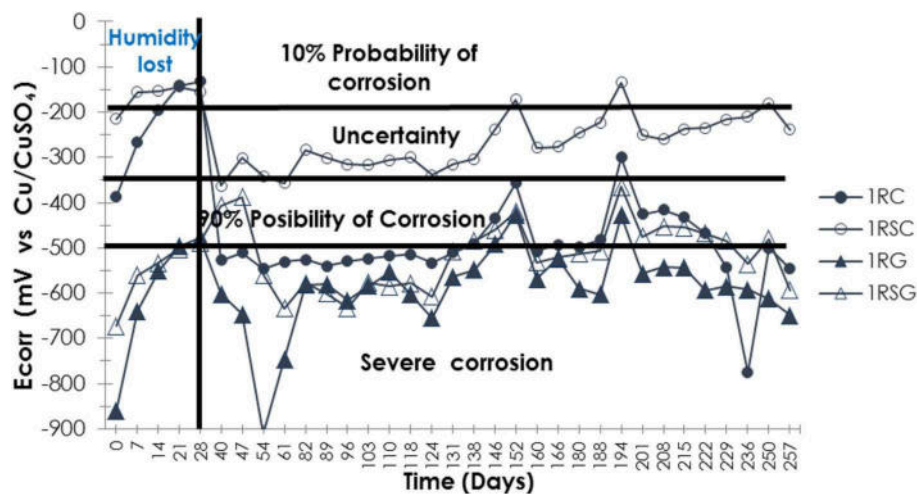

FIGURE 4 | E_{corr} specimens in soil type MH with 1% of NaCl.

performance against corrosion, however for the specimen made with normal cement (CPC 30R), specimen 1RC with AISI 1018 steel, presents until the day 140 values of E_{corr} more negative of -500 mV, indicating severe corrosion according to the standard, having a passivation period to the end to present an E_{corr} up to -550 mV, for the case of specimens with galvanized steel, 1RG y 1RSG, both presented a homogeneous behavior throughout the monitoring period, with E_{corr} values more negative than -500 mV, to have a period of instability fluctuating between -350 and -500 mV until day 200, for there to present a tendency to more negative values until the end of the exposure period, these results are similar to previous research works (Maslehuddin et al., 2007), which reports that in concrete specimens exposed for more than 400 days to a soil with 1 wt.% NaCl, the values of E_{corr} fluctuated in a range between -400 and -500 mV, specimens

of concrete made with cement Type I (CPC-30R) and Type V (CPC 30R-RS).

In Figure 5 it is shown as increasing the aggressive agent (NaCl) to 2 wt.% in the soil, the corrosive aggressiveness of the soil increases, causing in the specimen 2RC (AISI 1018-CPC 30R), present an E_{corr} of -490 mV for day 40 until reaching values of -550 mV on day 96, values indicating according to the standard ASTM C-876-15 severe corrosion, after day 100 it presents a period of passivation with more positive E_{corr} values, with a value of -320 mV on day 152, indicating uncertainty that corrosion of the reinforcing steel is occurring, for the last 100 days of monitoring present stable E_{corr} values of a range of -450 and -490 mV, indicating according to ASTM C-875-15 a 90% probability of corrosion of specimen 2RC, the specimen 2RSC (AISI 1018-CPC 30R RS), this presents a behavior very

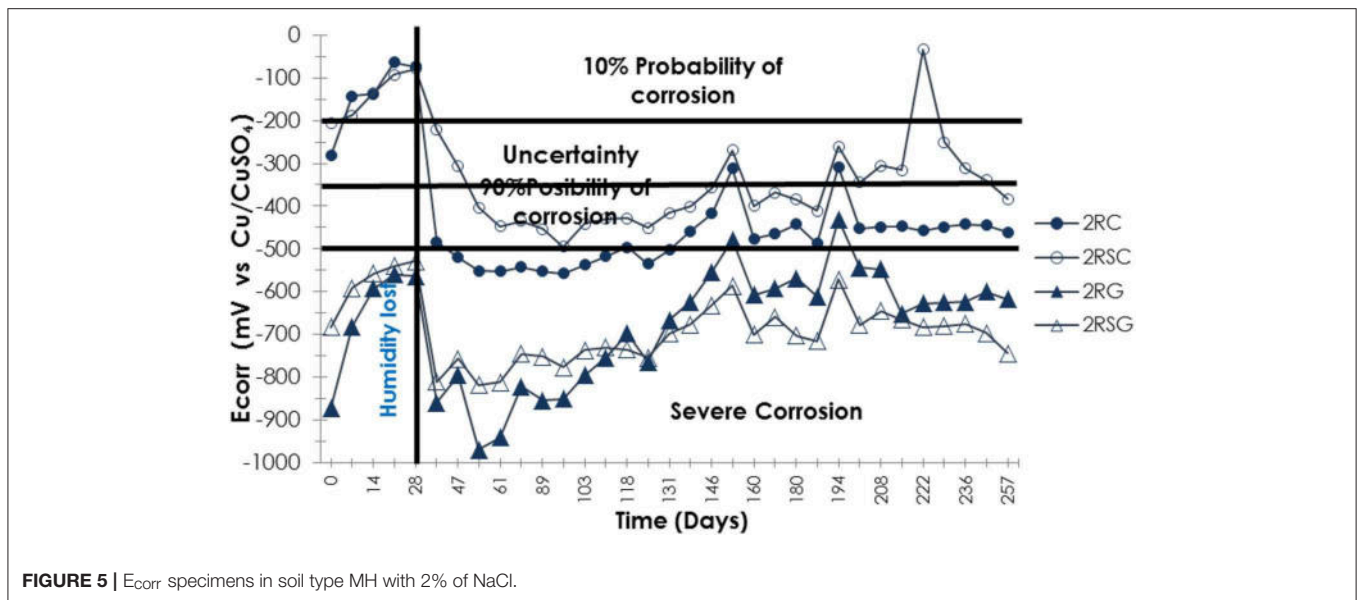

FIGURE 5 | E_{corr} specimens in soil type MH with 2% of NaCl.

similar to the specimen 2RC, with three significant periods, at the beginning with an activation period from day 40 to 96 with E_{corr} values tending to be more negative, values in a range of -220 to -495 mV, the second period corresponding to the passivation of the reinforcing steel from day 103 to day 152, with E_{corr} values of -450 mV to more positive, up to -270 mV, to enter a final period in the last 100 days of exposure with E_{corr} values indicating 90% probability of corrosion and uncertainty, it is identified as mentioned above a behavior similar to specimen 2RC but with a greater protection to the corrosion which is attributed to with a denser matrix and lower permeability of the mixture concrete with CPC-30R-RS, because the E_{corr} values of specimen 2RSC are 20% more noble than those reported by the specimen 2RC. As in **Figure 4**, the corrosion resistance offered by the concrete made with CPC-30R-RS by physical and mechanical properties of the mixture made with, to the AISI 1018 carbon steel embedded in specimen 1RSC, in the specimen 2RSC also presents protection against corrosion, but the protection against corrosion is lower, due to the increase of the aggressive agent present in the soil, 2% NaCl. The specimen 2RG (galvanized and normal cement CPC 30R), presents when coming into contact with the aggressive medium, soil type MH contaminated with 2% NaCl, E_{corr} values -820 mV on day 40, up to -970 mV on day 54, presenting more positive values from day 82 to 118, with values from -854 to -696 mV, identifying promptly a period of passivation from day 124 to day 152 passing from E_{corr} of -755 to -478 mV, to present in the last 100 days just like the specimens with steel AISI 1018 (2RC and 2RSC), a semi-stable period with E_{corr} values in a range of -550 and -665 mV, indicating according to the standard that is developing a severe corrosion. In the specimen 2RSG (galvanized steel and CPC 30R RS), is identified a behavior similar to the specimen 2RSC, but with more noble E_{corr} values (more positive), presenting from days 40 to 61 values from -756 to -810 mV, with a period of passivation from day 82 to day 152, passing from an E_{corr} of -745 to -586 mV, to have the last

100 days values in a range of -644 to -744 mV, also indicating severe corrosion.

Figure 6 shows the behavior of the corrosion potential (E_{corr}), of the specimens exposed in soil type MH but with a concentration of 3 wt.% of NaCl as aggressive agent, when comparing these results with those obtained from buried specimens in the soil in the natural state **Figure 3** (without NaCl), as well as soils with 1 and 2% NaCl (**Figures 4, 5**), it can be affirmed that the percentage of 3 wt.% of NaCl present in the soil type MH is determinant to increase in great magnitude the corrosive aggressiveness of the soil. When performing the analysis of the results, the specimen 3RC (AISI 1018- CPC 30R) presents a period of activation of the corrosion of the day 40 to the 138, with E_{corr} values in a range from -560 to -590 mV, with a better performance of the specimen 3RSC (AISI 1018- CPC 30R RS), presenting in the same period E_{corr} values of -450 to -519 mV, this indicates severe corrosion according to ASTM C-876-15, after day 138 both specimens experience until the end of monitoring an unstable period with corrosion potentials between -450 and -540 mV, fluctuating between 90% probability of corrosion and severe corrosion, but always prevailing with better performance the elaborated specimen with sulfate resistant cement (CPC 30R RS). Also the specimen 3RSG (Galvanized Steel-CPC 30R RS) presents the best performance against corrosion, at the beginning with a period of fall of the potential of day 40 to 61, going from a potential of -620 to -784 mV, to later present positive value of E_{corr} until reaching -594 mV on day 146, and present in the last 100 days of exposure a stable behavior with E_{corr} from -600 to 700 mV, indicating severe corrosion. For the specimen 3RG (galvanized steel-CPC 30R) passes from a corrosion potential of -686 mV on day 40 to $-1,113$ mV on day 103, to present a tendency to more positive values of corrosion potentials until -520 mV in the day 152, presenting from day 157 until the day 250 a stable behavior, with corrosion potentials ranging from -620 to -600 mV, presenting

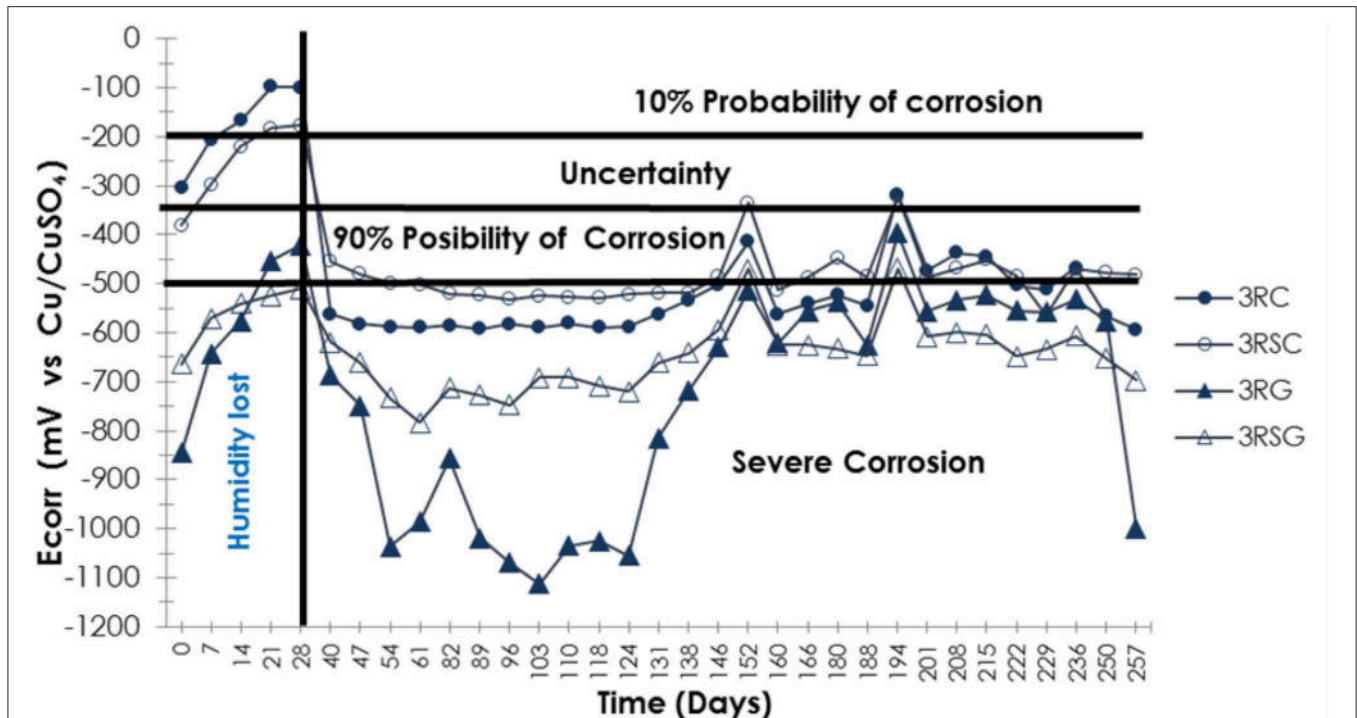

FIGURE 6 | E_{corr} specimens in soil type MH with 3% of NaCl.

TABLE 5 | Level of corrosion in accordance to I_{corr} .

Corrosion rate (I_{corr}) $\mu A/cm^2$	Level of corrosion
<0.1	Despicable (passivity)
0.1–0.5	Moderate
0.5–1	High
>1	Very high

a drastic fall at day 257 with a potential of -998 mV. A similar study was used the specimens were cracked by flexural stress so that a crack width of 1 mm was produced in a pre-formed notch area with the apex of the crack reaching the reinforcement. Then the specimens were exposed to weekly wet-dry cycles (2 days dry followed by 5 days wet) in a 10% NaCl solution, where values of E_{corr} , for specimens with concrete without any addition, in a range of $-1,000$ a -900 mV, in the first 5 cycles, to go down to values of -850 to -780 mV in the cycle 12 (Tittarelli et al., 2016), this values are in agreement with the E_{corr} values of the present study, most particularly when the soil has a concentration of 3 wt.% NaCl.

DISCUSSION

Corrosion Current Density (I_{corr})

Monitoring and interpretation of the corrosion current density (I_{corr}) was performed based on Durar NetWork Specifications (Troconis de Rincón, 1997) (see Table 5).

Figure 7 presents the results obtained from I_{corr} of reinforced concrete specimens with AISI 1018 carbon steel and galvanized steel after more than 250 days of exposure in a soil type MH. The I_{corr} results agree with what is reported in Figure 3 with corrosion potentials in the 4 specimens with a tendency to more positive indicating a passivation of reinforcing steel. The specimen 0RC (AISI 1018-CPC 30R) in the step curing presented an I_{corr} of 1.1 to $0.35 \mu A/cm^2$, to continue with a tendency to less aggressive corrosion levels, associated this behavior to the formation of the passive film in the reinforcing steel, presenting on day 229 an I_{corr} below 0.1 and of $0.08 \mu A/cm^2$ in the day 257, indicating a despicable level of corrosion according to the Table 5. In the case of the specimen 0RSC (AISI 1018-CPC 30R RS) this presented a behavior very similar to the specimen 0RC, however it is identified a greater corrosion protection associated with physical and mechanical properties of the mixture concrete made with CPC 30R RS, presenting the concrete mix lower permeability, because their I_{corr} values are lower, reporting the 0RSC specimen in the curing step an initial I_{corr} of 0.75 to $0.2 \mu A/cm^2$, moving from a high to moderate level of corrosion, continuing in a process of passivation until day 82 with I_{corr} of $0.12 \mu A/cm^2$, from day 89 to 103 there is a small activation with an I_{corr} of $0.27 \mu A/cm^2$, but maintaining a moderate level of corrosion, as of day 110 the values of I_{corr} descend steadily until reaching an I_{corr} of $0.09 \mu A/cm^2$ on day 215, indicating a despicable level of corrosion, which was maintained until the end of the monitoring. The 0RSG specimen (galvanized steel-CPC 30R RS) present a behavior very similar to the 0RSC specimens, but with a slightly better performance

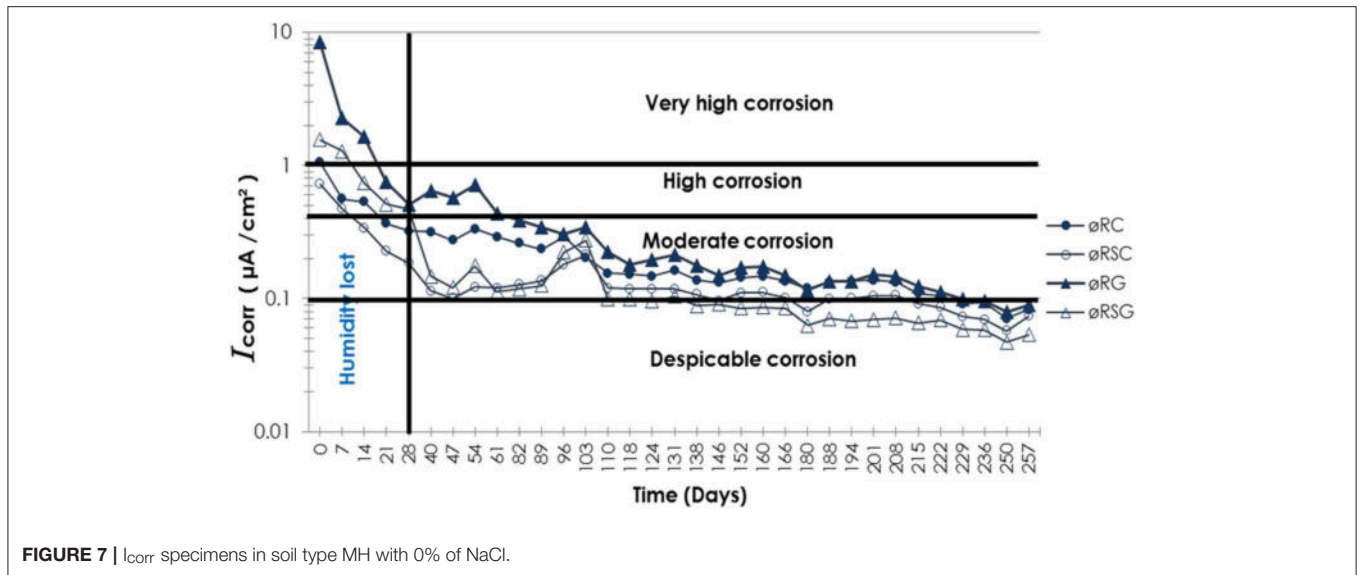

FIGURE 7 | I_{corr} specimens in soil type MH with 0% of NaCl.

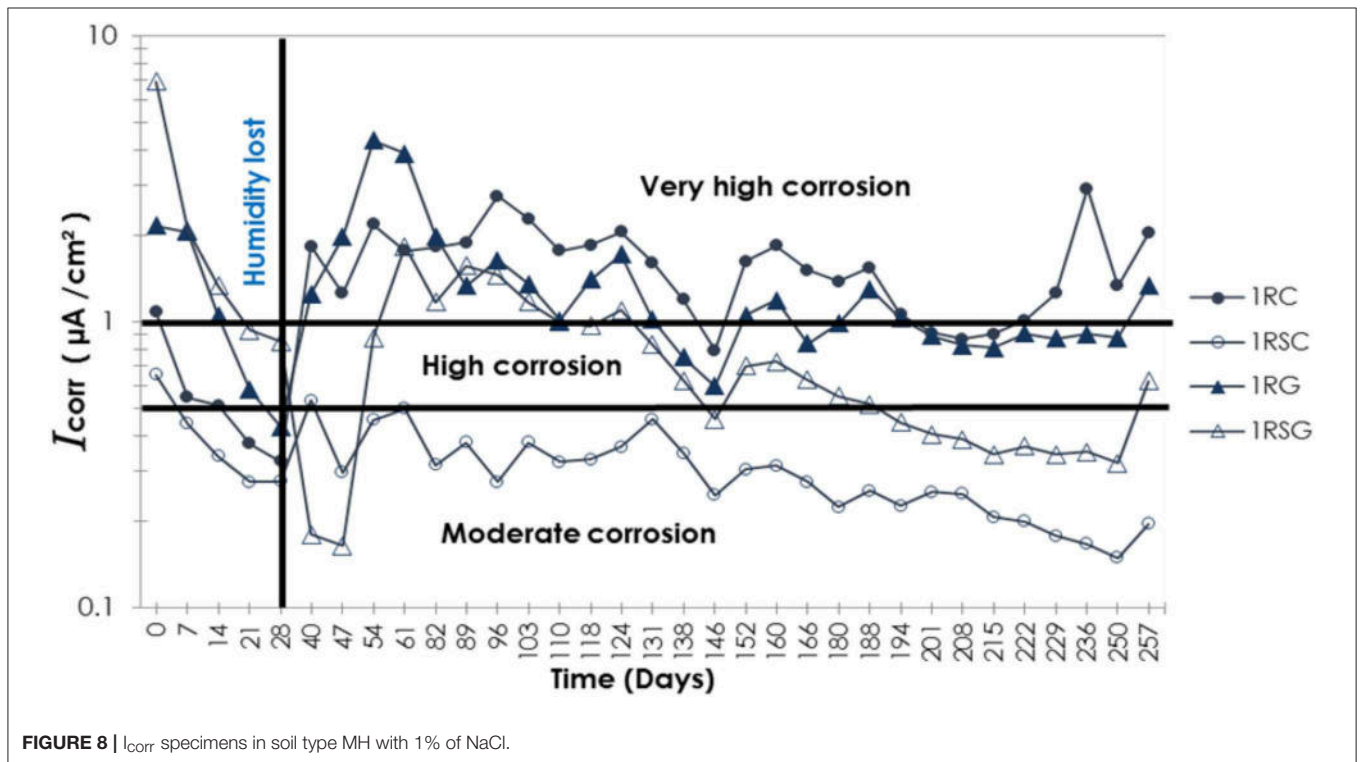

FIGURE 8 | I_{corr} specimens in soil type MH with 1% of NaCl.

against corrosion, with I_{corr} values of 1.56 to 0.47 $\mu\text{A}/\text{cm}^2$ in the step curing, to remain at a moderate corrosion level from day 40 to 131, with I_{corr} values between 0.27 and 0.10 $\mu\text{A}/\text{cm}^2$, to continue the steel passivation process, with values lower than 0.10 $\mu\text{A}/\text{cm}^2$ from day 138 and present at the end of the monitoring an I_{corr} of 0.05 $\mu\text{A}/\text{cm}^2$. The specimen ORG (galvanized steel and normal cement CPC 30R), also exhibit the same passivation behavior over time as the specimen ORSG, however their I_{corr} values are higher, presenting I_{corr} values of

8.48 $\mu\text{A}/\text{cm}^2$ at 0.5 $\mu\text{A}/\text{cm}^2$, in the curing stage, with a high corrosion level from day 40 to 54 with I_{corr} values $> 0.5 \mu\text{A}/\text{cm}^2$, for later present a continuous decrease of I_{corr} values, with a moderate level of corrosion from day 61 to day 236, I_{corr} of 0.44 and 0.10 $\mu\text{A}/\text{cm}^2$ respectively, and have a despicable corrosion level with values of 0.09 $\mu\text{A}/\text{cm}^2$ in the last 20 days of the monitoring.

In analyzing the results of the corrosion rate of **Figure 8**, the specimen 1RC (AISI 1018-CPC 30R) presents in its curing stage

I_{corr} values of $1.08 \mu\text{A}/\text{cm}^2$ on day 1 and $0.53 \mu\text{A}/\text{cm}^2$ for day 28, indicating a process of passivation of the steel in that period, however when the specimen was buried in soil type MH with 1 wt.% NaCl, the I_{corr} values were $>1 \mu\text{A}/\text{cm}^2$ from day 40, until values of maximum of $2.8 \mu\text{A}/\text{cm}^2$ for day 96 of exposition, this I_{corr} values indicating a very high level of corrosion, after these maximum I_{corr} values, a passivation stage was presented with a constant decrease in I_{corr} until reaching a high corrosion level on day 146 with a I_{corr} of $0.80 \mu\text{A}/\text{cm}^2$, to increase the I_{corr} to a range between 1.8 and $1.1 \mu\text{A}/\text{cm}^2$ on days 152 to 188, completing the monitoring stage (257 days) with an I_{corr} of $2.0 \mu\text{A}/\text{cm}^2$, confirming the presence of a very high level of corrosion. For the case of specimen 1RSC, the protection related to the have greater mechanical resistance and present a more impermeable matrix the mixture concrete made with CPC 30R RS, this specimen presents values of I_{corr} lower than specimen 1RC, present in the curing step I_{corr} of 0.65 to $0.28 \mu\text{A}/\text{cm}^2$, the protection remaining throughout the 257 days of exposure, with values I_{corr} below $0.50 \mu\text{A}/\text{cm}^2$ until the day 131, and from day 138 with a continuous trend at lower values of I_{corr} , to reach an I_{corr} of $0.20 \mu\text{A}/\text{cm}^2$ at the end of the monitoring, indicating a moderate level of corrosion. The specimen 1RSG (galvanized steel-CPC 30R RS) presents I_{corr} values of $0.18 \mu\text{A}/\text{cm}^2$ until day 47, to present an activation period between days 61 and 124 with $I_{\text{corr}} >1 \mu\text{A}/\text{cm}^2$, values indicating a very high level of corrosion, after this period it presents a stage of passivation by continuously decreasing its I_{corr} to $0.15 \mu\text{A}/\text{cm}^2$ at the end of the monitoring, value indicating a moderate level corrosion. The specimen 1RG (AISI 1018-CPC 30R) presents a period of a very high level of corrosion from the day 40 to the 131, with I_{corr} values in a range of 4.32 and $1 \mu\text{A}/\text{cm}^2$, to report from there until the end of the monitoring an instability of the system, fluctuating from a high level to a very high level of corrosion with I_{corr} values between 0.6 and $1.3 \mu\text{A}/\text{cm}^2$ in that period, observing the attack due to 1 wt.% of NaCl present in the soil.

In **Figure 9** it is observed that by increasing the concentration of NaCl to 2 wt.%, the corrosive aggressiveness of soil is considerably increased, presenting the specimens 2RC, 2RG, and 2RSG an unfavorable behavior against corrosion by being buried in said soil, with magnitudes of $I_{\text{corr}} >3 \mu\text{A}/\text{cm}^2$ in the first 100 days, the 2RG and 2RSG specimens presented later I_{corr} in a range of 2.25 to $1.1 \mu\text{A}/\text{cm}^2$, magnitudes that still indicate a very high level of corrosion according to what is indicated in **Table 4** and no benefit is identified due to the concrete mix made with cement CPC 30R, as had been observed in the specimens exposed to soil in the natural state (**Figure 7**), and in specimens exposed to soil with 1 wt.% NaCl (**Figure 8**). The specimen that presented the worst performance against corrosion was the 2RC, this specimen present I_{corr} value of 2.22 to $2.56 \mu\text{A}/\text{cm}^2$, from day 100 until the end of the monitoring. It is noteworthy that the benefit of the use of concrete with sulfate resistant cement was presented in the specimen reinforced with steel AISI 1018, the 2RSC specimen presented a passivation stage with I_{corr} lower than $0.25 \mu\text{A}/\text{cm}^2$ until day 47, with an activation period with a maximum I_{corr} of $1.6 \mu\text{A}/\text{cm}^2$ on day 96 and present after the day 100 another period of passivation or greater resistance to the corrosion in comparison with the other specimens, with I_{corr} values in a range of 0.9 to $0.42 \mu\text{A}/\text{cm}^2$ until the end of the monitor indicating a high and moderate level of corrosion.

Figure 10 shows the results of the corrosion kinetics of the exposed specimens in fine soil type MH with a 3 wt.% NaCl, it has an unfavorable behavior against the corrosion of all the specimens in the first 103 days, with an increase in the magnitudes of I_{corr} upon contact with the aggressive medium, the 3RSC specimen has values $>3.3 \mu\text{A}/\text{cm}^2$ and of $3.6 \mu\text{A}/\text{cm}^2$ the specimen 3RC, after day 103 there is a period of decrease in the I_{corr} , presenting the specimen 3RC values $<1 \mu\text{A}/\text{cm}^2$ from day 194 to 236 to reach an I_{corr} of $1.5 \mu\text{A}/\text{cm}^2$ for the end of the monitoring, for the case of the 3RSC specimen

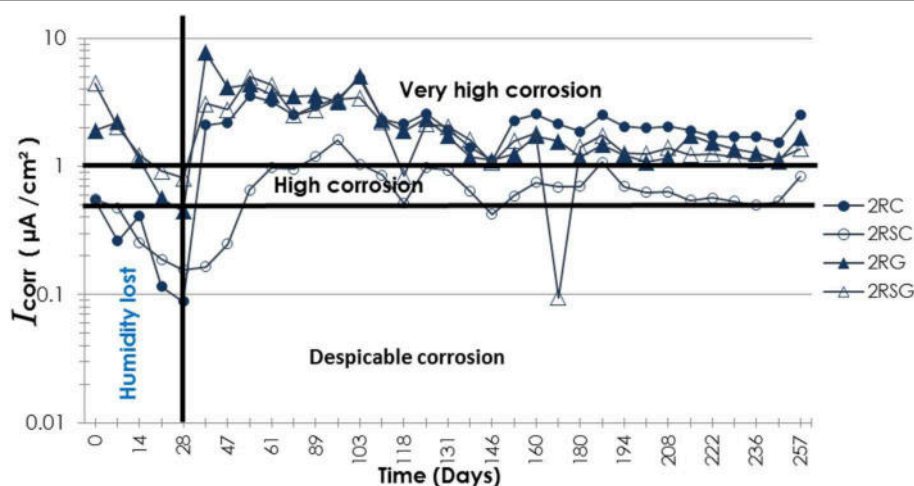

FIGURE 9 | I_{corr} specimens in soil type MH with 2% of NaCl.

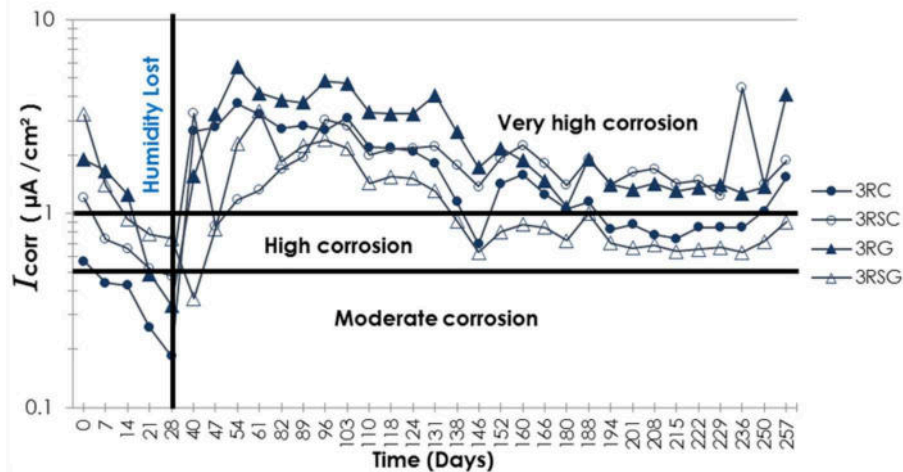

FIGURE 10 | I_{corr} specimens in soil type MH with 3% of NaCl.

its I_{corr} was maintained from day 110 until the end of the monitoring above $1 \mu\text{A}/\text{cm}^2$, which indicates for both specimens a very high level of corrosion. In the case of specimens with galvanized steel, the specimen 3RG having values of I_{corr} above $1 \mu\text{A}/\text{cm}^2$, with a maximum of $5.7 \mu\text{A}/\text{cm}^2$ for day 54 and a minimum of $1.1 \mu\text{A}/\text{cm}^2$ on day 180 and maintained at an average of $1.3 \mu\text{A}/\text{cm}^2$ until the end of the exposure time, I_{corr} values indicating a very high level of corrosion, in contrast the specimen 3RSG present a behavior of greater resistance to the corrosion, with an activation period with maximum I_{corr} of $2.4 \mu\text{A}/\text{cm}^2$ on day 96, to present after day 100 a passivation period with a decrease of I_{corr} to $0.6 \mu\text{A}/\text{cm}^2$ in the day 146, indicating a high level of corrosion and remain in that range until the end of the monitoring with a small tendency to values close to $1 \mu\text{A}/\text{cm}^2$, which would indicate a tendency to a very high level of corrosion as the other specimens, confirming the corrosive aggressiveness of the soil by increasing its NaCl content to 3 wt.%.

Some studies of corrosion in concrete reinforced with galvanized steel exposed marine, reported the beneficial effect of the use of inhibitors (Fayala et al., 2013), which increase the corrosion resistance of galvanized steel, this study showed that the evolution of polarization resistance values, measured on reinforced mortar specimens after 3, 6, and 12 cycles of wet-dry exposure to 3% NaCl solution, show that the corrosion resistance of galvanized rebars is improved in presence of DEA with respect to the control specimen, contrary to the use of SN which accelerates the corrosion process. However according to the results of the present investigation, in particular in the results obtained when the soil presented 2 and 3 wt.% of NaCl, these results confirm what is mentioned by the scientific community (Pokorny et al., 2017), indicates that there is a negative effect of zinc corrosion products is described—concrete curing and hardening of concrete is retarded in their presence, their growth can cause local

disintegration. The review points out many contradicting results and therefore the fact that real consequences of galvanized reinforcement corrosion are not, even at present day, known. Use of galvanized zinc coatings for protection of conventional steel reinforcement cannot, to this day, be considered clearly beneficial and research regarding the topic to be finished.

CONCLUSIONS

The main conclusions of this research work are:

1. The level of corrosion that can be present in reinforced concretes exposed to soil type MH, common in the Xalapa region—southeast México, is negligible because it is not a corrosive soil in its natural state.
2. When the soil have a 1 wt.% of NaCl, the specimens moderate to high corrosion levels in AISI 1018 carbon steel and galvanized steel, a small benefit against corrosion was identified and related to the properties of a denser and less impermeable matrix that presented the concrete mix made with cement CPC 30R RS (Type V), when the soil is in its natural state (without NaCl) or with 1 wt.% NaCl, with greater resistance to corrosion in both steels.
3. When the concentration of NaCl in the soil type MH was increased to 2 and 3 wt.%, are presented corrosion levels from high to very high in all concrete specimens, reinforced with AISI 1018 carbon steel as reinforced with galvanized steel.
4. It is very important to consider the concentration of aggressive agents such as chlorides (NaCl) present in the soil, that in concentrations of more than 2 wt.% NaCl per soil weight, the probability that the foundation based on reinforced concrete will suffer premature corrosion damage of the reinforcing steel is very high.

5. It is necessary to stipulate as a requirement for the construction of Civil Works, the chemical analysis of the soil where such works are to be displaced, to determine the concentration of aggressive agents such as NaCl, to design concrete resistant to attack by this type of aggressive agents and that contribute to increase the durability of the civil infrastructure from the elements of the foundation.

DATA AVAILABILITY STATEMENT

All datasets generated for this study are included in the manuscript/supplementary files.

REFERENCES

- ACI 211.1 (2004). *Proporciónamiento de Mezclas, Concreto Normal, Pesado y Masivo ACI 211.1*. Cd. de México: IMCYC, 28–34.
- Adekunle, S., Ahmad, S., Maslehuddin, M., and Al-Gahtani, H. J. (2015). Properties of SCC prepared using natural pozzolana and industrial wastes as mineral fillers. *Cem. Concr. Comp.* 62, 125–133. doi: 10.1016/j.cemconcomp.2015.06.001
- Almeraya, F., Zambrano, P., Borunda, A., Martínez, A., Estupiñan, F., and Gaona, C. (2013). “Inspección y monitoreo de corrosión a chimeneas de concreto reforzado,” in *Corrosión y Preservación de la Infraestructura Industrial*, eds B. V. Salas and M. S. Wiener (Barcelona: OmniaScience), 207–224. doi: 10.3926/oms.76
- Alonso, M. C., Luna, F. J., and Criado, M. (2019). Corrosion behavior of duplex stainless steel reinforcement in ternary binder concrete exposed to natural chloride penetration. *Constr. Build. Mater.* 19, 385–395. doi: 10.1016/j.conbuildmat.2018.12.036
- Ann, K. Y., and Song, H. W. (2007). Chloride threshold level for corrosion of steel in concrete. *Corros. Sci.* 49, 4113–4133. doi: 10.1016/j.corsci.2007.05.007
- ASTM C 1064/C1064M–08 (2008). *Standard Test Method for Temperature of Freshly Mixed Hydraulic-Cement Concrete*. West Conshohocken, PA: ASTM International.
- ASTM C 876–15 (2015). *Standard Test Method for Corrosion Potentials of Uncoated Reinforcing Steel in Concrete*. West Conshohocken, PA: ASTM International.
- ASTM C127–15 (2015). *Standard Test Method for Relative Density (Specific Gravity) and Absorption of Coarse Aggregate*. West Conshohocken, PA: ASTM International.
- ASTM C128–15 (2015). *Standard Test Method for Relative Density (Specific Gravity) and Absorption of Fine Aggregate*. West Conshohocken, PA: ASTM International.
- ASTM C192/C192M–18 (2016). *Standard Practice for Making and Curing Concrete Test Specimens in the Laboratory*. West Conshohocken, PA: ASTM International.
- ASTM C29/C29M–07 (2007). *Standard Test Method for Bulk Density (“Unit Weight”) and Voids in Aggregate*. West Conshohocken, PA: ASTM International.
- ASTM C33/C33M–16e1 (2016). *Standard Specification for Concrete Aggregates*. West Conshohocken, PA: ASTM International.
- ASTM G 59–97 (2014). *Standard Test Method for Conducting Potentiodynamic Polarization Resistance Measurements*. West Conshohocken, PA: ASTM International.
- Babae, M., and Castel, A. (2018). Chloride diffusivity, chloride threshold, and corrosion initiation in reinforced alkali-activated mortars: role of calcium, alkali, and silicate content. *Cem. Concr. Res.* 111, 56–71. doi: 10.1016/j.cemconres.2018.06.009
- Baltazar, M. A., Santiago, G., Moreno, V. M., Croche, R., De la Garza, M., Estupiñan, F., et al. (2016). Electrochemical behaviour of galvanized steel embedded in concrete exposed to sand contaminated with NaCl. *Int. J. Electrochem. Sci.* 11, 10306–10319. doi: 10.20964/2016.12.28
- Bastidas, D. M., Criado, M., Fajardo, S., La Iglesia, A., and Bastidas, J. M. (2015). Corrosion inhibition mechanism of phosphates for early-age reinforced mortar in the presence of chlorides. *Cem. Concr. Comp.* 61, 1–6. doi: 10.1016/j.cemconcomp.2015.04.009
- Bellezza, T., Malavolta, M., Quaranta, A., Ruffini, N., and Roventi, G. (2006). Corrosion behaviour in concrete of three differently galvanized steel bars. *Cem. Concr. Comp.* 28, 246–255. doi: 10.1016/j.cemconcomp.2006.01.011
- Caré, S., and Raharinaivo, A. (2007). Influence of impressed current on the initiation of damage in reinforced mortar due to corrosion of embedded Steel. *Cem. Concr. Res.* 37, 1598–1612. doi: 10.1016/j.cemconres.2007.08.022
- Chaleea, W., Jaturapitakkul, C., and Chindaprasirt, P. (2009). Predicting the chloride penetration of fly ash concrete in seawater. *Marine Struct.* 22, 341–353. doi: 10.1016/j.marstruc.2008.12.001
- Cheng, A., Huang, R., Wu, J. K., and Chen, C. H. (2005). Effect of rebar coating on corrosion resistance and bond strength of reinforced concrete. *Constr. Build. Mater.* 19, 404–412. doi: 10.1016/j.conbuildmat.2004.07.006
- Criado, M., Bastidas, D. M., Fajardo, S., Fernandez, A., and Bastidas, J. M. (2011). Corrosion behaviour of a new low-nickel stainless steel embedded in activated fly ash mortars. *Cem. Concr. Comp.* 33, 644–652. doi: 10.1016/j.cemconcomp.2011.03.014
- Das, B. M. (2006). *Principio de Ingeniería de Cimentaciones*. Cd. De México: Thomson, 68–71.
- De Vera, G., Antón, C., López, M. P., and Climent, M. A. (2017). Depassivation time estimation in reinforced concrete structures exposed to chloride ingress: a probabilistic approach. *Cem. Concr. Comp.* 79, 21–33. doi: 10.1016/j.cemconcomp.2016.12.012
- Duarte, R. G., Castela, A. S., Neves, R., Freire, L., and Montemor, M. F. (2014). Corrosion behavior of stainless steel rebars embedded in concrete: an electrochemical impedance spectroscopy study. *Electrochim. Acta* 124, 218–224. doi: 10.1016/j.electacta.2013.11.154
- Fajardo, S., Bastidas, D. M., Criado, M., Romero, M., and Bastidas, J. M. (2011). Corrosion behaviour of a new low-nickel stainless steel in saturated calcium hydroxide solution. *Constr. Build. Mater.* 25, 4190–4196. doi: 10.1016/j.conbuildmat.2011.04.056
- Fayala, I., Dhoubi, L., Nóvoa, X. R., and Ouedzou, M. (2013). Effect of inhibitors on the corrosion of galvanized steel and on mortar properties. *Cem. Concr. Comp.* 35, 181–189. doi: 10.1016/j.cemconcomp.2012.08.014
- Hung Mo, K. H., Goh, S. H., Alengaram, U. J., Visintin, P., and Jumaat, M. Z. (2017). Mechanical, toughness, bond and durability-related properties of lightweight concrete reinforced with steel fibres. *Mater. Struct.* 50, 1–14. doi: 10.1617/s11527-016-0934-1
- Kayali, O., and Yeomans, S. R. (2000). Bond of ribbed galvanized reinforcing steel in concrete. *Cem. Concr. Comp.* 22, 459–467. doi: 10.1016/S0958-9465(00)00049-4
- Kwon, S. J., Lee, H. S., Karthick, S., Saraswathy, V., and MinYang, H. (2017). Long-term corrosion performance of blended cement concrete in the

AUTHOR CONTRIBUTIONS

CH and RC carried out the electrochemical test. CG-T, LL, and FO performed the analysis of the results. MB-Z, JM-R, and FA-C wrote the article and are advisors to the research group.

ACKNOWLEDGMENTS

The authors thank PRODEP for the support granted by the SEP, to the Academic Body UV-CA-458 Sustainability and Durability of Materials for Civil Infrastructure, within the framework of the 2018 Call for the Strengthening of Academic Bodies with IDCA 28593 and the work group UANL-CA-316.

- marine environment—A real-time study. *Constr. Build. Mater.* 154, 349–360. doi: 10.1016/j.conbuildmat.2017.07.237
- Landa, A. E., Croche, R., Márquez, S., Galván, R., Gaona, C., Almeraya, F., et al. (2018a). Correlation of compression resistance and rupture module of a concrete of ratio $w/c = 0.50$ with the corrosion potential, electrical resistivity and ultrasonic pulse speed. *ECS Trans.* 84, 217–227. doi: 10.1149/08401.0217ecst
- Landa, A. E., Croche, R., Márquez, S., Villegas, R., Ariza, H. A., Estupiñan, F., et al. (2018b). Corrosion behavior 304 and 316 stainless steel as reinforcement in sustainable concrete based on sugar cane bagasse ash exposed to Na_2SO_4 . *ECS Trans.* 84, 179–188. doi: 10.1149/08401.0179ecst
- Liang, M. T., and Lan, J. J. (2005). Reliability analysis for the existing reinforced concrete pile corrosion of bridge substructure. *Cem. Concr. Res.* 35, 540–550. doi: 10.1016/j.cemconres.2004.05.010
- Luo, H., Donga, C. F., Li, X. G., and Xiaoa, K. (2012). The electrochemical behaviour of 2205 duplex stainless steel in alkaline solutions with different pH in the presence of chloride. *Electrochim. Acta.* 64, 211–220. doi: 10.1016/j.electacta.2012.01.025
- Mahyuddin, R. W., Wai Hoe, K., and Noor, F. A. (2013). Strength and durability of coconut-fiber-reinforced concrete in aggressive environments. *Constr. Build. Mater.* 38, 554–566. doi: 10.1016/j.conbuildmat.2012.09.002
- Maslehuddin, M., Al-Zahrani, M. M., Ibrahim, M., Al-Methel, M. H., and Al-Idi, S. H. (2007). Effect of chloride concentration in soil on reinforcement corrosion. *Constr. Build. Mater.* 21, 1825–1832. doi: 10.1016/j.conbuildmat.2006.05.019
- Melchers, R. E., and Li, C. Q. (2009). Reinforcement corrosion initiation and activation times in concrete structures exposed to severe marine environments. *Cem. Concr. Res.* 39, 1068–1076. doi: 10.1016/j.cemconres.2009.07.003
- Monticelli, C., Criado, M., Fajardo, S., Bastidas, J. M., Abbottoni, M., and Balbo, A. (2014). Corrosion behavior of low Ni austenitic stainless steel in carbonated chloride-polluted alkali-activated fly ash mortar. *Cem. Concr. Res.* 55, 49–58. doi: 10.1016/j.cemconres.2013.09.014
- NMX-C-083-ONNCCE-2014 (2014). *Industria de la Construcción - Concreto - Determinación de la Resistencia a la Compresión de Especímenes - Método de Ensayo*. Cd. México, México: ONNCCE.
- NMX-C-156-ONNCCE-2010 (2010). *Determinación de Revenimiento en Concreto Fresco*. Cd. México, México: ONNCCE.
- NMX-C-162-ONNCCE-2014 (2014). *Industria de la Construcción - Concreto Hidráulico - Determinación de la Masa Unitaria, Cálculo del Rendimiento y Contenido de Aire del Concreto Fresco por el Método Gravimétrico*. Cd. México, México: ONNCCE.
- NMX-C-414-ONNCCE-2014 (2014). *Industria de la Construcción - Cementantes Hidráulicos - Especificaciones y Métodos de Ensayo*. Cd. México, México: ONNCCE.
- Núñez, R., Buelna, J., Barrios, C., Gaona, C., and Almeraya, F. (2012). Corrosion of modified concrete with sugar cane bagasse ash. *Int. J. Corros.* 12, 1–5. doi: 10.1155/2012/451864
- Pokorny, P., Tej, P., and Kouřil, M. (2017). Evaluation of the impact of corrosion of hot-dip galvanized reinforcement on bond strength with concrete—A review. *Constr. Build. Mater.* 132, 271–289. doi: 10.1016/j.conbuildmat.2016.11.096
- Pradhan, B. (2014). Corrosion behavior of steel reinforcement in concrete exposed to composite chloride-sulfate environment. *Constr. Build. Mater.* 72, 398–410. doi: 10.1016/j.conbuildmat.2014.09.026
- Roventi, G., Bellezze, T., Giuliani, G., and Conti, C. (2014). Corrosion resistance of galvanized steel reinforcements in carbonated concrete: effect of wet-dry cycles in tap water and in chloride solution on the passivating layer. *Cem. Concr. Res.* 65, 76–84. doi: 10.1016/j.cemconres.2014.07.014
- Sadrmtomtazi, A., Tahmouresi, B., and Amooie, M. (2017). Permeability and mechanical properties of binary and ternary cementitious mixtures. *Adv. Concr. Constr.* 5, 423–436. doi: 10.12989/acc.2017.5.5.423
- Santiago, G., Baltazar, M. A., Galindo, A., Cabral, J. A., Estupiñan, F. H., Zambrano, P., et al. (2013). Anticorrosive efficiency of primer applied in carbon steel AISI 1018 as reinforcement in a soil type MH. *Int. J. Electrochem. Sci.* 8, 8490–8501. Available online at: <http://www.electrochemsci.org/papers/vol8/80608490.pdf>
- Santiago, G., Baltazar, M. A., Galván, R., López, L., Zapata, F., Zambrano, P., et al. (2016a). Electrochemical evaluation of reinforcement concrete exposed to soil type SP contaminated with sulphates. *Int. J. Electrochem. Sci.* 11, 4850–4864. doi: 10.20964/2016.06.31
- Santiago, G., Baltazar, M. A., Olguín, J., López, L., Galván, R., Ríos, A., et al. (2016b). Electrochemical evaluation of a stainless steel as reinforcement in sustainable concrete exposed to chlorides. *Int. J. Electrochem. Sci.* 11, 2994–3006. doi: 10.20964/110402994
- Šavija, B., and Lukovic, M. (2016). Carbonation of cement paste: understanding, challenges, and opportunities. *Constr. Build. Mater.* 117, 285–301. doi: 10.1016/j.conbuildmat.2016.04.138
- Shaheen, F., and Pradhan, B. (2017). Influence of sulfate ion and associated cation type on steel reinforcement corrosion in concrete powder aqueous solution in the presence of chloride ions. *Cem. Concr. Res.* 91, 73–86. doi: 10.1016/j.cemconres.2016.10.008
- Song, H. W., and Saraswathy, V. (2007). Corrosion monitoring of reinforced concrete structures -A review. *Int. J. Electrochem. Sci.* 2, 1–28. Available online at: <http://www.electrochemsci.org/papers/vol2/2010001.pdf>
- Tittarelli, F., Mobili, A., and Bellezze, T. (2016). “The effect of fly ash on the corrosion behaviour of galvanised steel rebars in concrete,” in *Proceedings of the International Conference on Advanced Material Technologies* (Visakhapatnam, Andhra Pradesh, India). doi: 10.1088/1757-899X/225/1/012107
- Troconis de Rincon, O., Montenegro, J. C., Vera, R., Carvajal, A. M., de Gutiérrez, R. M., Saborio, E., et al. (2016). Reinforced concrete durability in marine environments DURACON project: long-term exposure. *Corrosion* 72, 824–833. doi: 10.5006/1893
- Troconis de Rincón, O., Uller, L., Alanis, I., Helene, P., Mejías de Gutiérrez, R., O’Rally, V. (1997). “Manual de inspección, evaluación y diagnóstico de corrosión en estructuras de concreto armado,” in *CYTED Program*, ed Red DURAR (Rio de Janeiro), 112–113.
- Uthaman, S., George, R. P., Vishwakarma, V., Harilal, M., and Philip, J. (2017). Enhanced seawater corrosion resistance of reinforcement in nanophase modified fly ash concrete. *Constr. Build. Mater.* 221, 232–243. doi: 10.1016/j.conbuildmat.2019.06.070
- Verbruggen, H., Terryn, H., and De Graeve, I. (2017). Inhibitor evaluation in different simulated concrete pore solution for the protection of steel rebars. *Constr. Build. Mater.* 124, 887–896. doi: 10.1016/j.conbuildmat.2016.07.115
- Wang, Z., Zeng, Q., Wang, L., Yao, Y., and Li, K. (2014). Corrosion of rebar in concrete under cyclic freeze-thaw and chloride salt action. *Constr. Build. Mater.* 53, 40–47. doi: 10.1016/j.conbuildmat.2013.11.063
- Williamson, J., and Burkan, O. (2016). The effect of simulated concrete pore solution composition and chlorides on the electronic properties of passive films on carbon steel rebar. *Corros. Sci.* 106, 82–95. doi: 10.1016/j.corsci.2016.01.027
- Zhang, W., Ba, H., and Chen, S. (2011). Effect of fly ash and repeated loading on diffusion coefficient in chloride migration test. *Constr. Build. Mater.* 25, 2269–2274. doi: 10.1016/j.conbuildmat.2010.11.016
- Zhao, G., Li, J., and Wei Shao, W. (2018). Effect of mixed chlorides on the degradation and sulfate diffusion of cast-in-situ concrete due to sulfate attack. *Constr. Build. Mater.* 181, 49–58. doi: 10.1016/j.conbuildmat.2018.05.251
- Zhu, W., and François, R. (2013). Effect of corrosion pattern on the ductility of tensile reinforcement extracted from a 26-year-old corroded beam. *Adv. Concr. Constr.* 1, 121–136. doi: 10.12989/acc.2013.01.2.121
- Zuquan, J., Wei, S., Yunsheng, Z., Jinyang, J., and Jianzhong, L. (2007). Interaction between sulfate and chloride solution attack of concretes with and without fly ash. *Cem. Concr. Res.* 37, 1223–1232. doi: 10.1016/j.cemconres.2007.02.016

Conflict of Interest: CH was employed by company ASPHALTPAVE S.A.

The remaining authors declare that the research was conducted in the absence of any commercial or financial relationships that could be construed as a potential conflict of interest.

Copyright © 2019 Baltazar-Zamora, Mendoza-Rangel, Croche, Gaona-Tiburcio, Hernández, López, Olguín and Almeraya-Calderón. This is an open-access article distributed under the terms of the Creative Commons Attribution License (CC BY). The use, distribution or reproduction in other forums is permitted, provided the original author(s) and the copyright owner(s) are credited and that the original publication in this journal is cited, in accordance with accepted academic practice. No use, distribution or reproduction is permitted which does not comply with these terms.